

FO-7 LOW PASS FILTER PWB ASSY,  
A1A5 (Sheet 2 of 4)

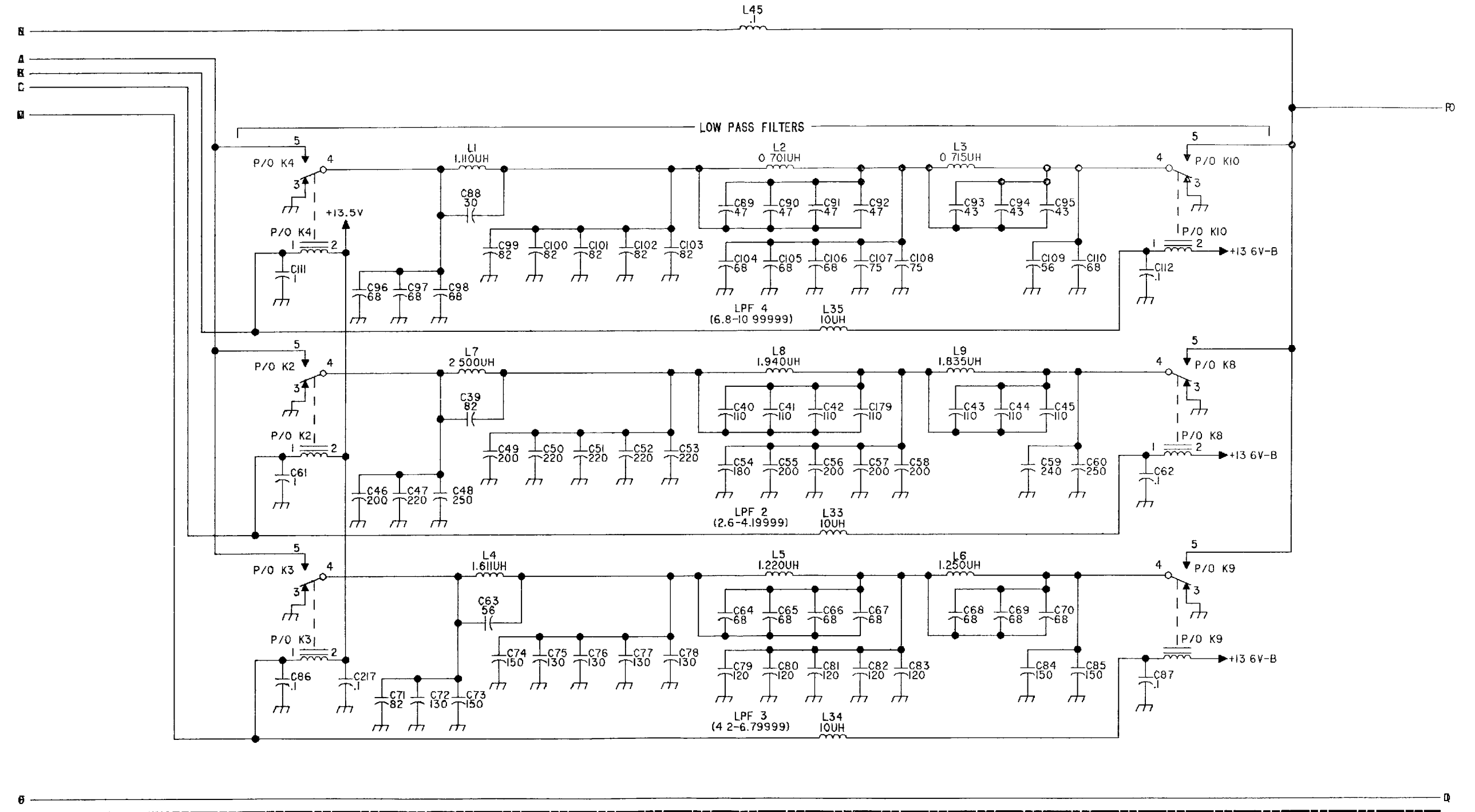



FO-7 LOW PASS FILTER PWB ASSY,  
A1A5 (Sheet 3 of 4)



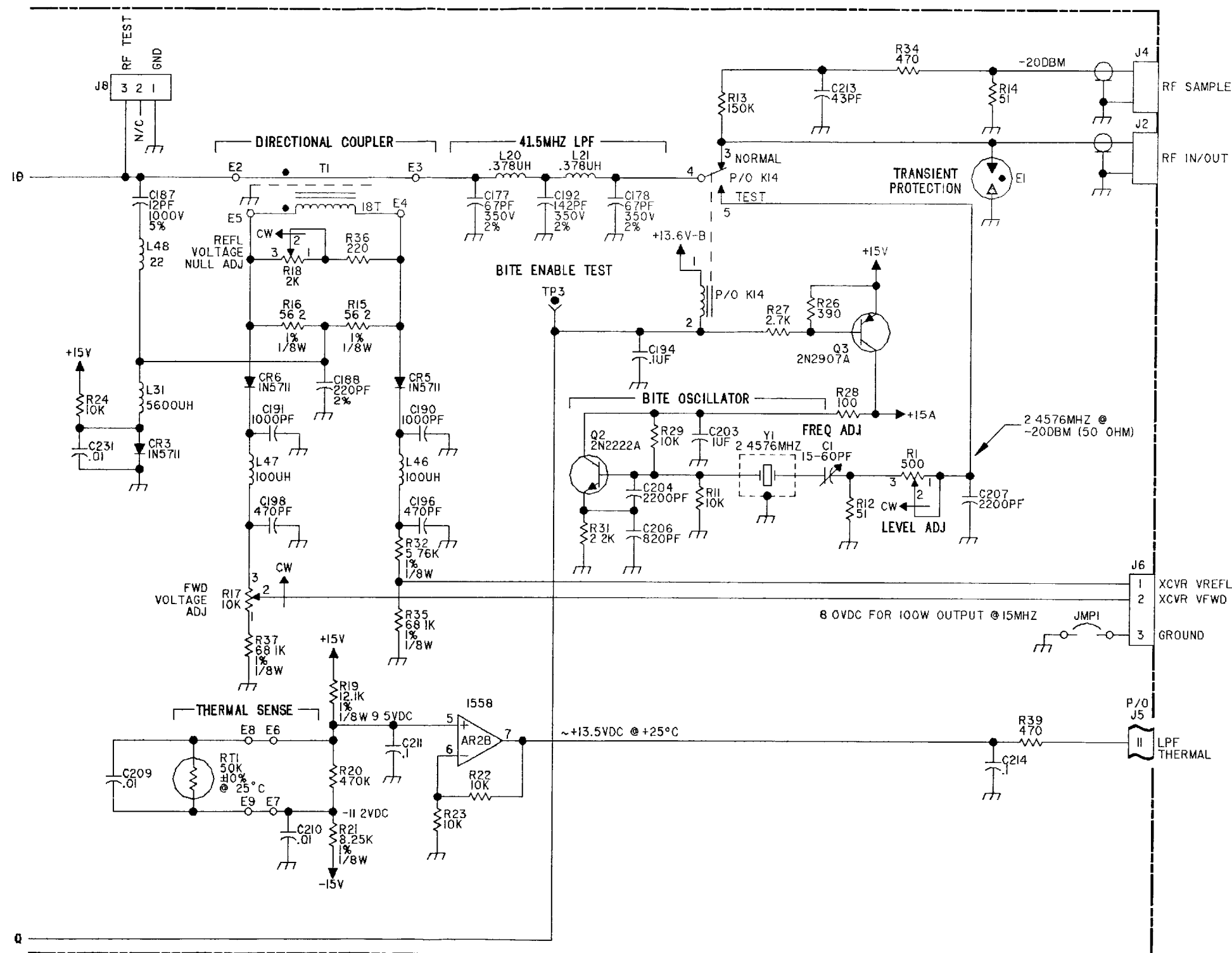

FO-7 LOW PASS FILTER PWB ASSY, A1A5 (Sheet 4 of 4)



NOTE: UNLESS OTHERWISE SPECIFIED:

1. PARTIAL REFERENCE DESIGNATIONS ARE SHOWN FOR DETAIL PARTS. PREFIX THESE WITH UNIT NO. AND/OR ASSEMBLY DESIGNATIONS SHOWN ON DRAWING TO OBTAIN COMPLETE DESIGNATIONS.
2. ALL RESISTOR VALUES ARE IN OHMS, 1/4W, ±5%
3. ALL CAPACITOR VALUES ARE IN MICROFARADS (µF).
4. ALL INDUCTANCE VALUES ARE IN MICROHENRIES (µH)
5. VENDOR PART NO. CALLOUTS ARE FOR REFERENCE ONLY. COMPONENTS ARE SUPPLIED PER PART NO. IN PARTS LIST
6. DC RESISTANCES OF INDUCTIVE ELEMENTS (CHOKES, COILS, MOTOR WINDINGS, ETC.) ARE LESS THAN 1 OHM.
7. PANEL DECALS ARE INDICATED BY BOLD TYPE IN A BOLD BOX, E.G., **ON/OFF**.
8. ALL RELAYS ARE SHOWN IN THE DE-ENERGIZED STATE.

HIGHEST REFERENCE DESIGNATION	
REFERENCE DESIGNATIONS NOT USED	

UNUSED GATES

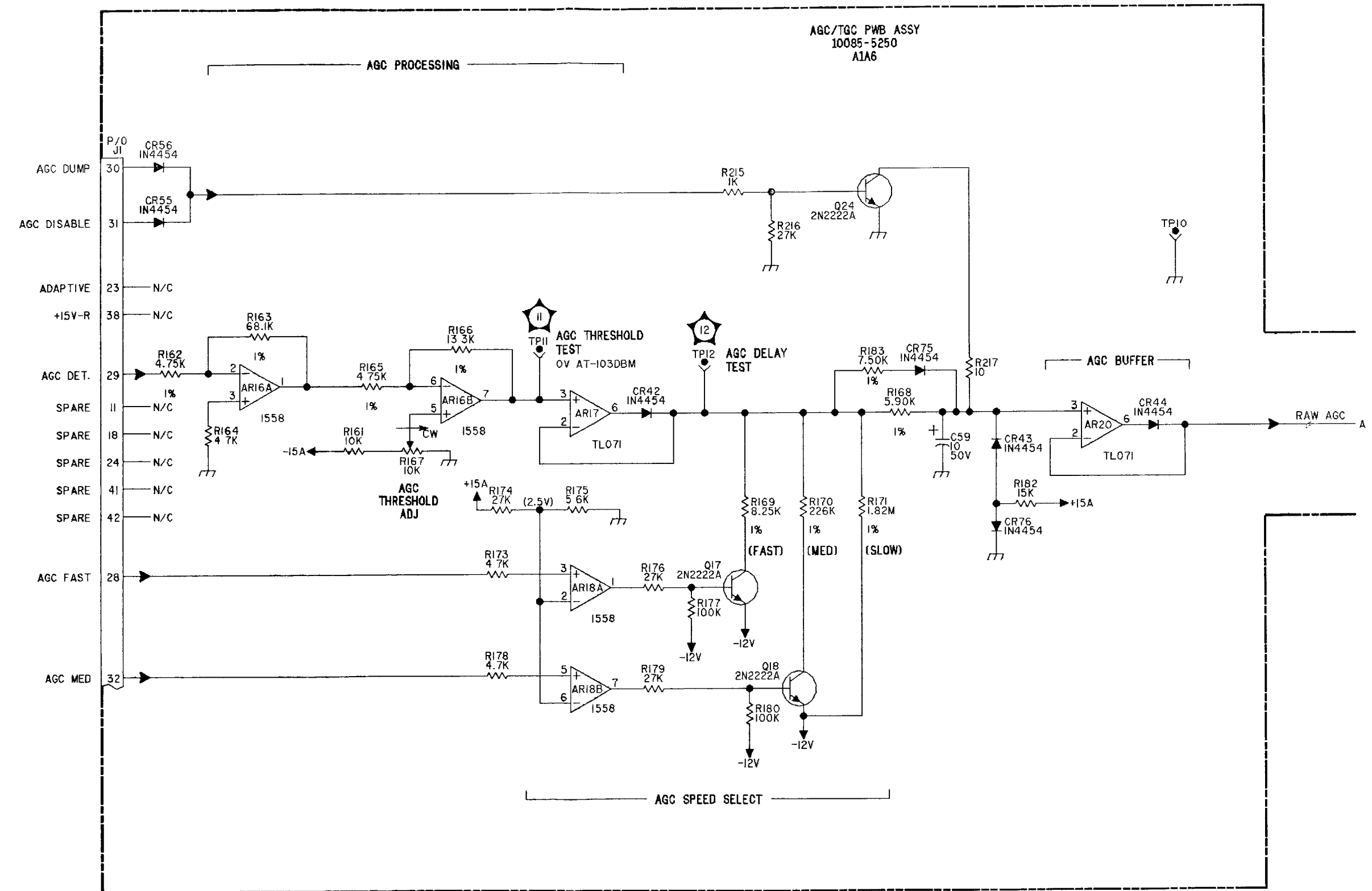
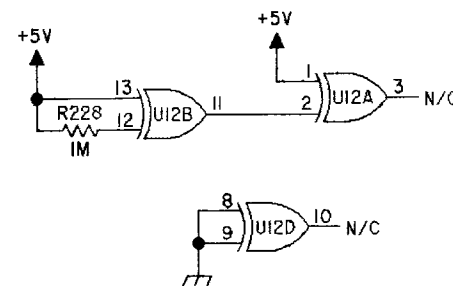
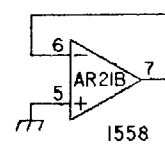

FO-8. AGC/TGC PWB ASSY, A1A6  
(Sheet 1 of 9)





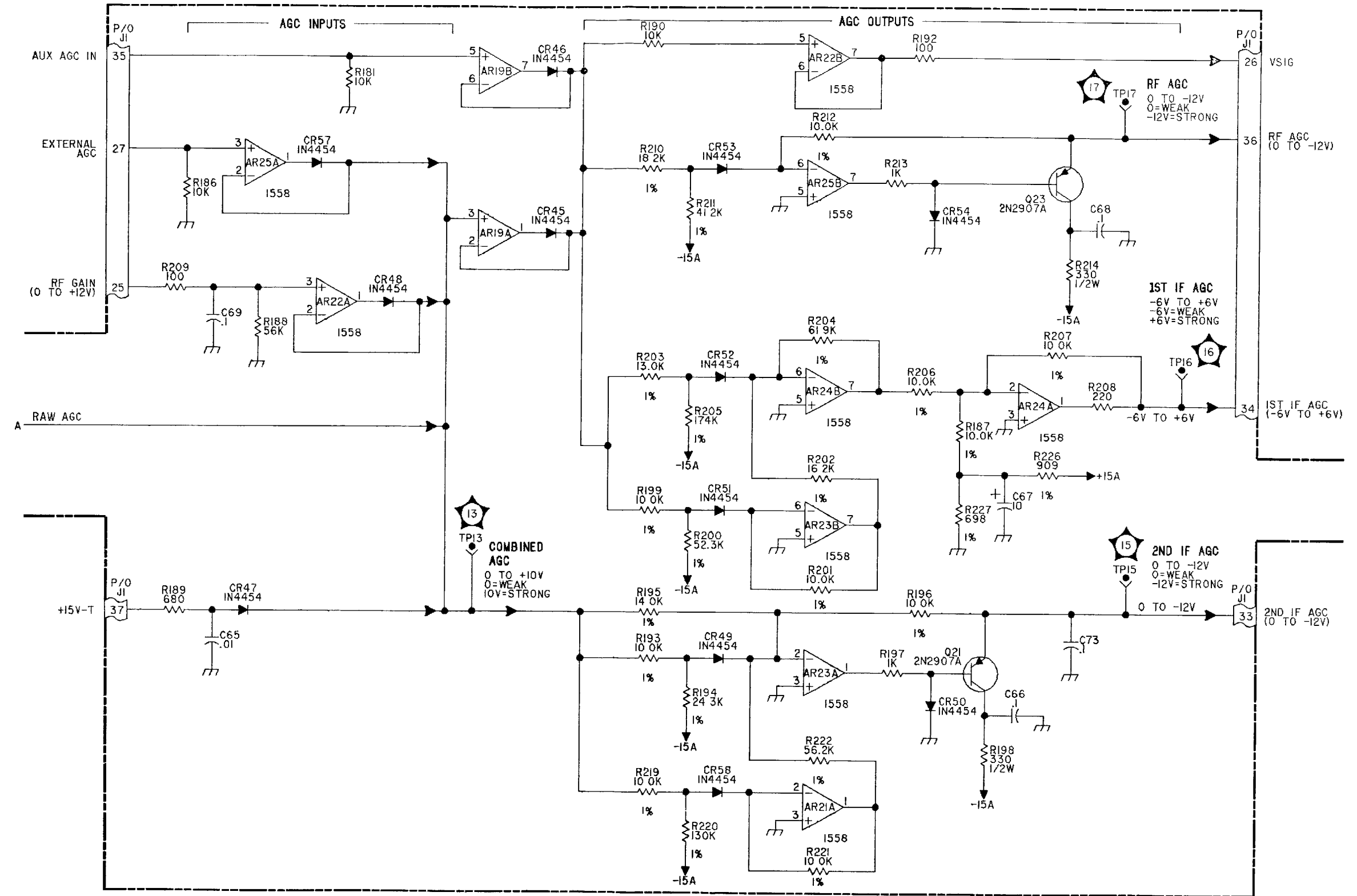

FO-8. AGC/TGC PWB ASSY, A1A6  
(Sheet 2 of 9)



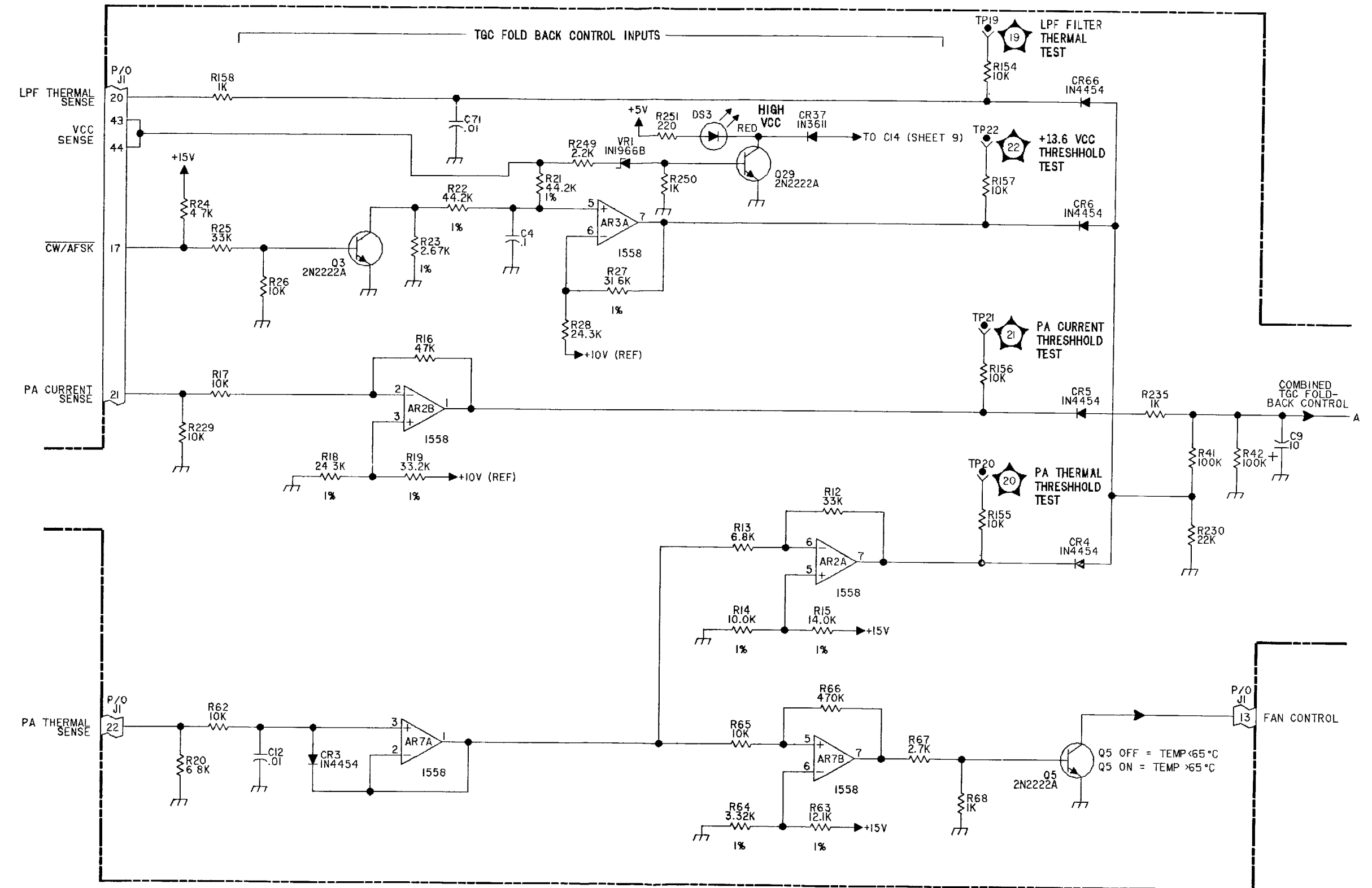

FO-8. AGC/TGC PWB ASSY, A1A6  
(Sheet 3 of 9)



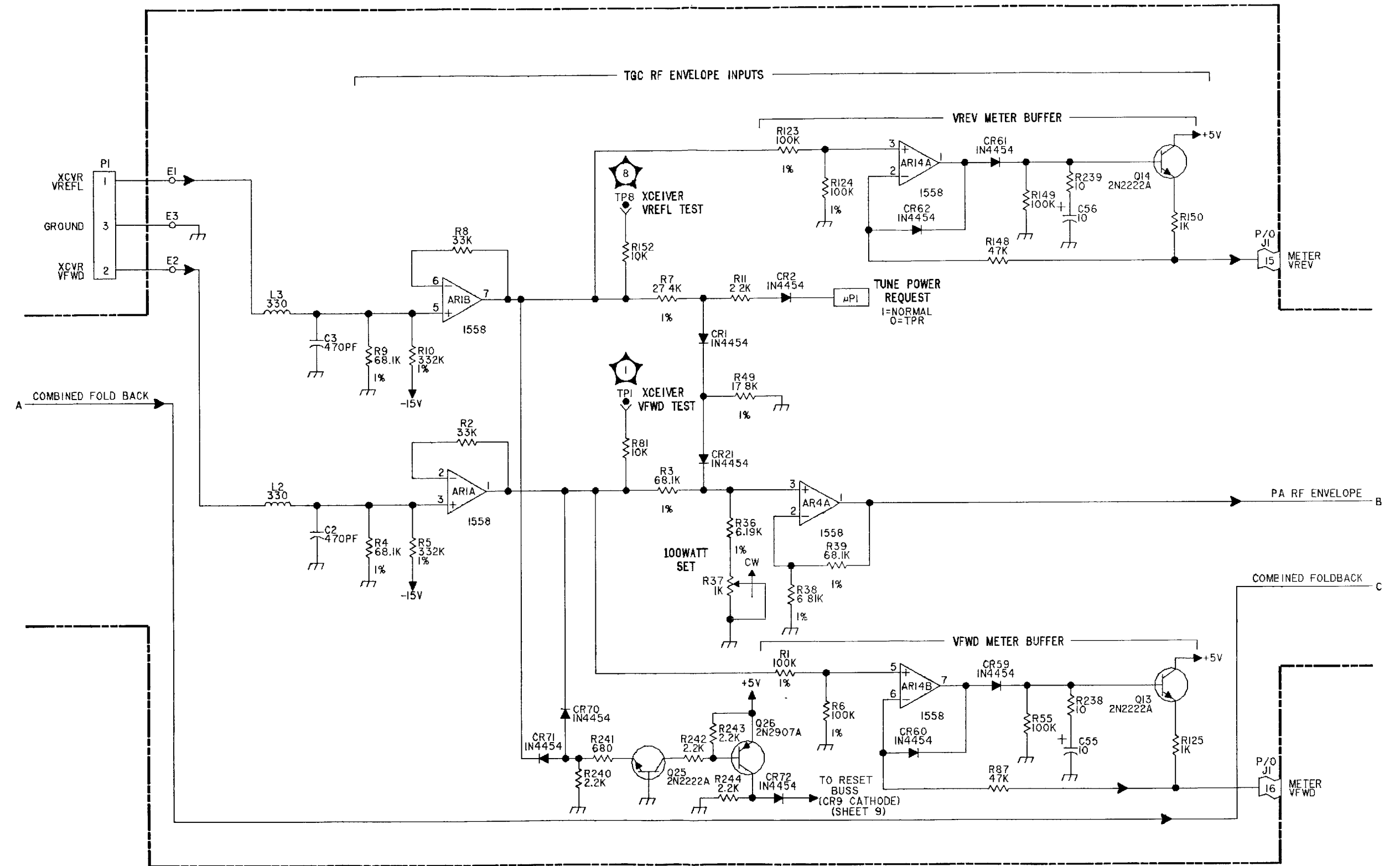

FO-8. AGC/TGC PWB ASSY, A1A6  
(Sheet 4 of 9)



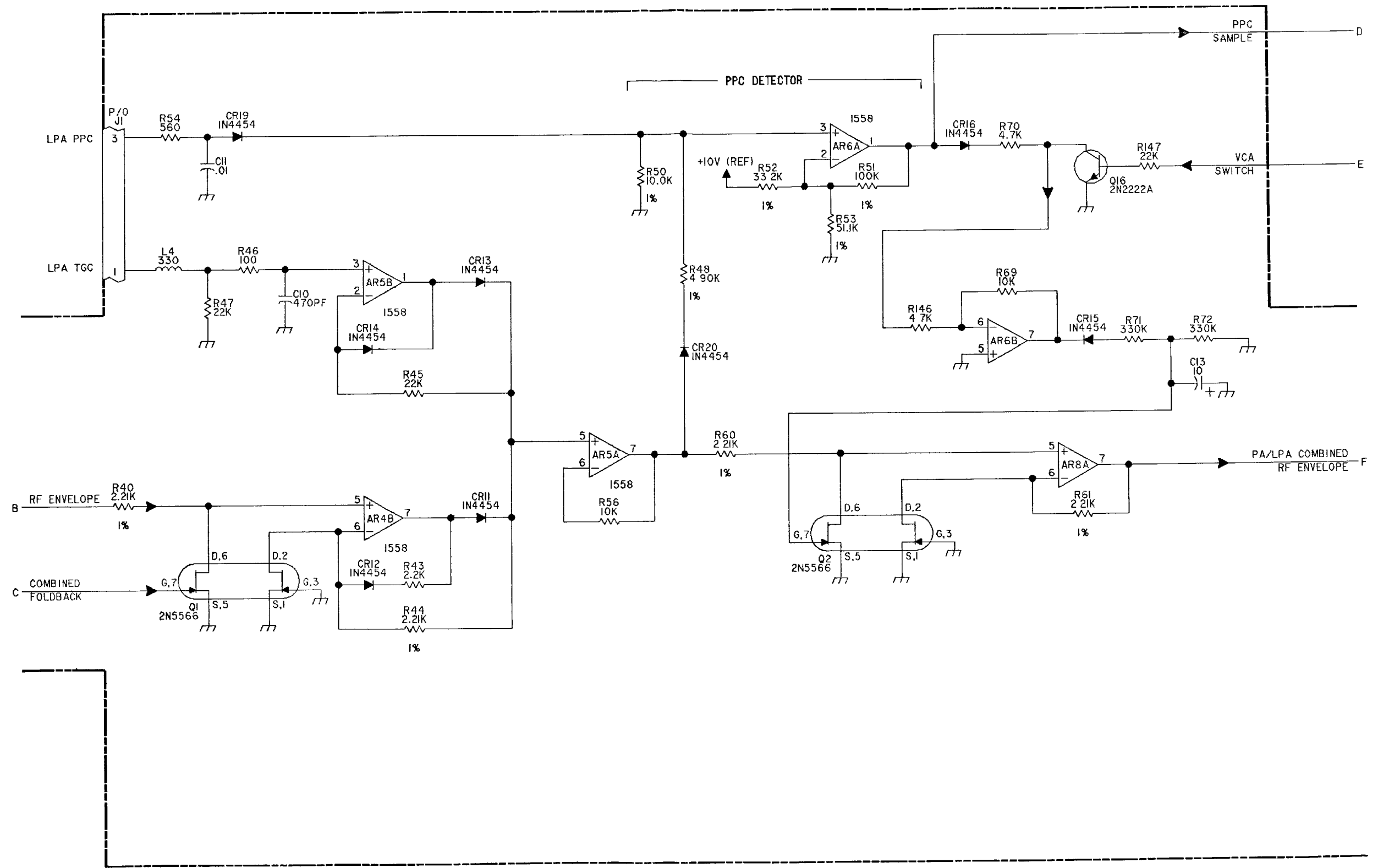

FO-8. AGC/TGC PWB ASSY, A1A6  
(Sheet 5 of 9)









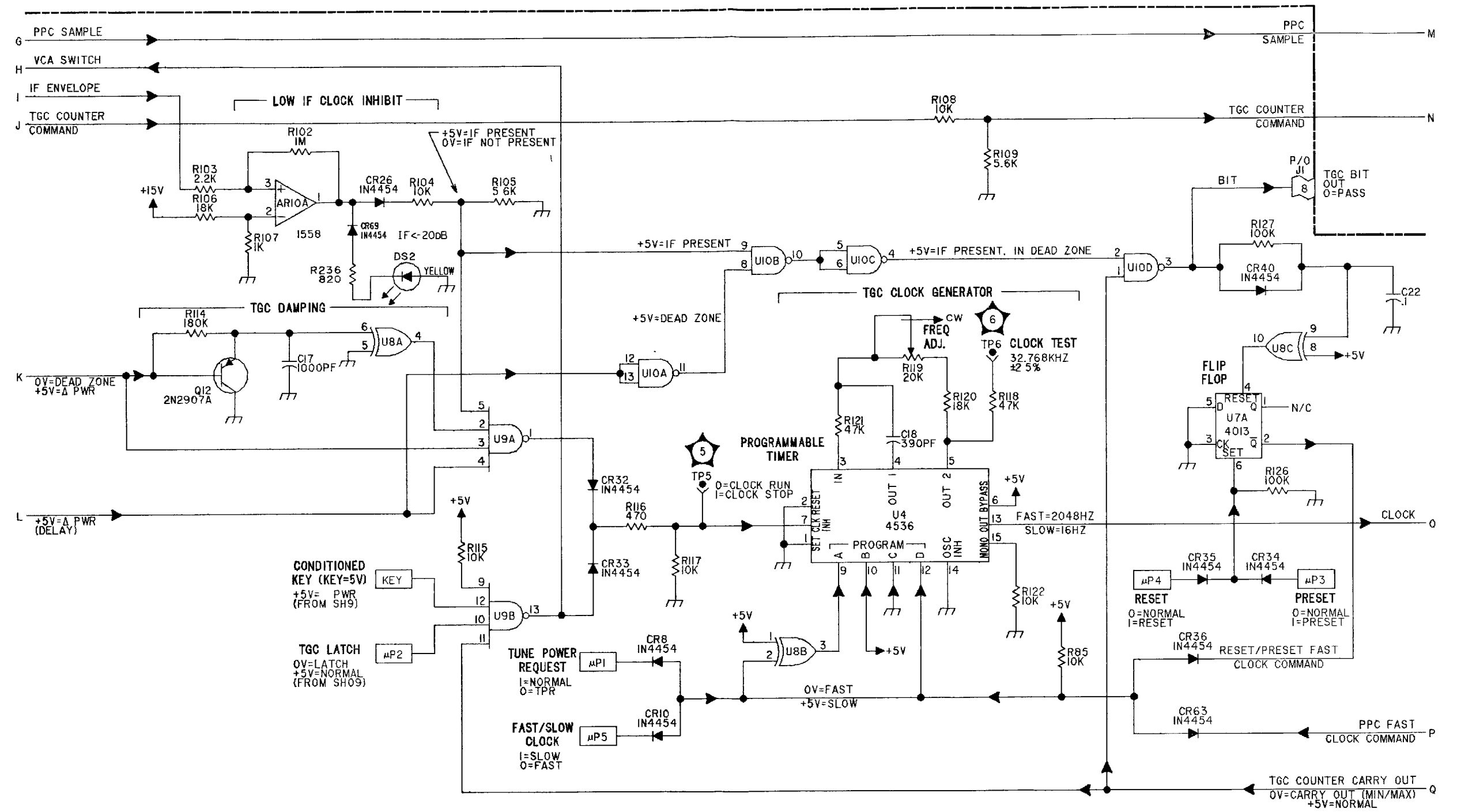

FO-8. AGC/TGC PWB ASSY, A1A6  
(Sheet 7 of 9)



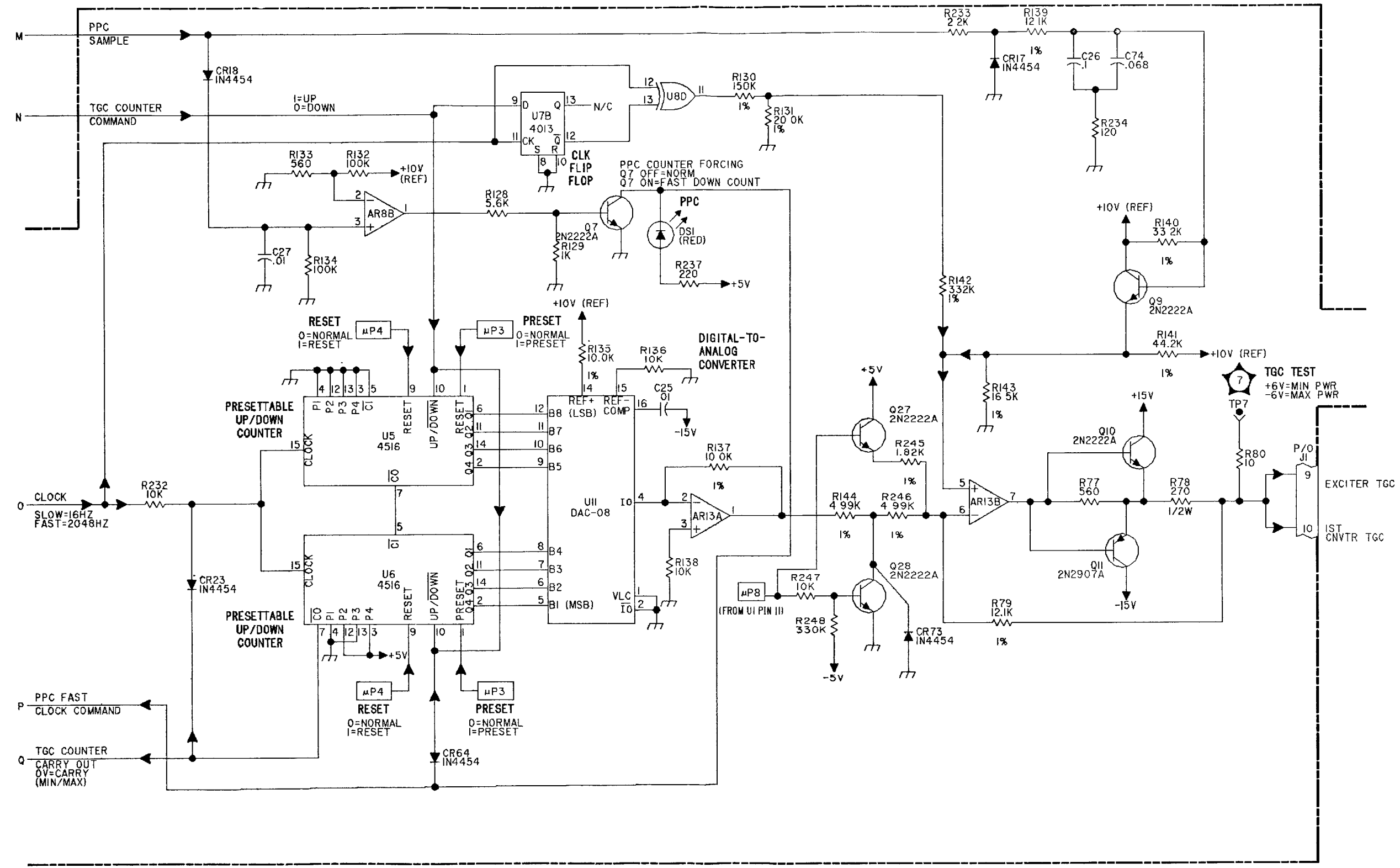

FO-8. AGC/TGC PWB ASSY, A1A6  
(Sheet 8 of 9)



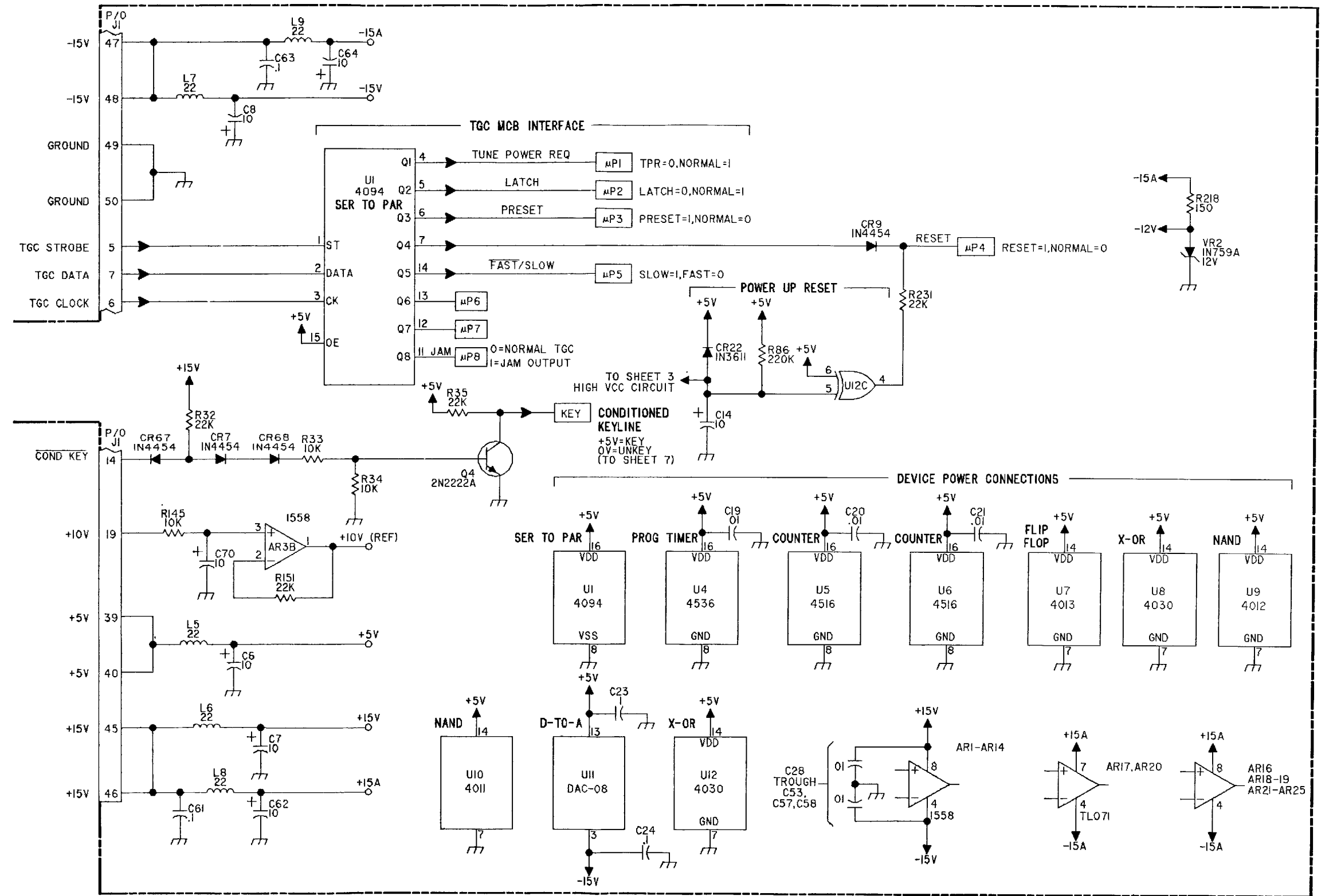

FO-8. AGC/TGC PWB ASSY, A1A6  
(Sheet 9 of 9)





- NOTE UNLESS OTHERWISE SPECIFIED:
- PARTIAL REFERENCE DESIGNATIONS ARE SHOWN FOR DETAIL PARTS. PREFIX THESE WITH UNIT NO. AND/OR ASSEMBLY DESIGNATIONS SHOWN ON DRAWING TO OBTAIN COMPLETE DESIGNATIONS.
  - ALL RESISTOR VALUES ARE IN OHMS, 1/4W, ±5%.
  - ALL CAPACITOR VALUES ARE IN MICROFARADS (UF).
  - ALL INDUCTANCE VALUES ARE IN MICROHENRIES (UH).
  - VENDOR PART NO. CALLOUTS ARE FOR REFERENCE ONLY. COMPONENTS ARE SUPPLIED PER PART NO. IN PARTS LIST.
  - DC RESISTANCES OF INDUCTIVE ELEMENTS (CHOKES, COILS, MOTOR WINDINGS, ETC.) ARE LESS THAN 1 OHM.
  - PANEL DECALS ARE INDICATED BY BOLD TYPE IN A BOLD BOX, E.G., **ON/OFF**.
  - ALL RELAYS ARE SHOWN IN THE DE-ENERGIZED STATE.
  - ALL AMPLIFIERS ARE DUAL 1558.
  - INDICATES PI CONNECTION AT PWB.

HIGHEST REFERENCE DESIGNATION			
REFERENCE DESIGNATIONS NOT USED			

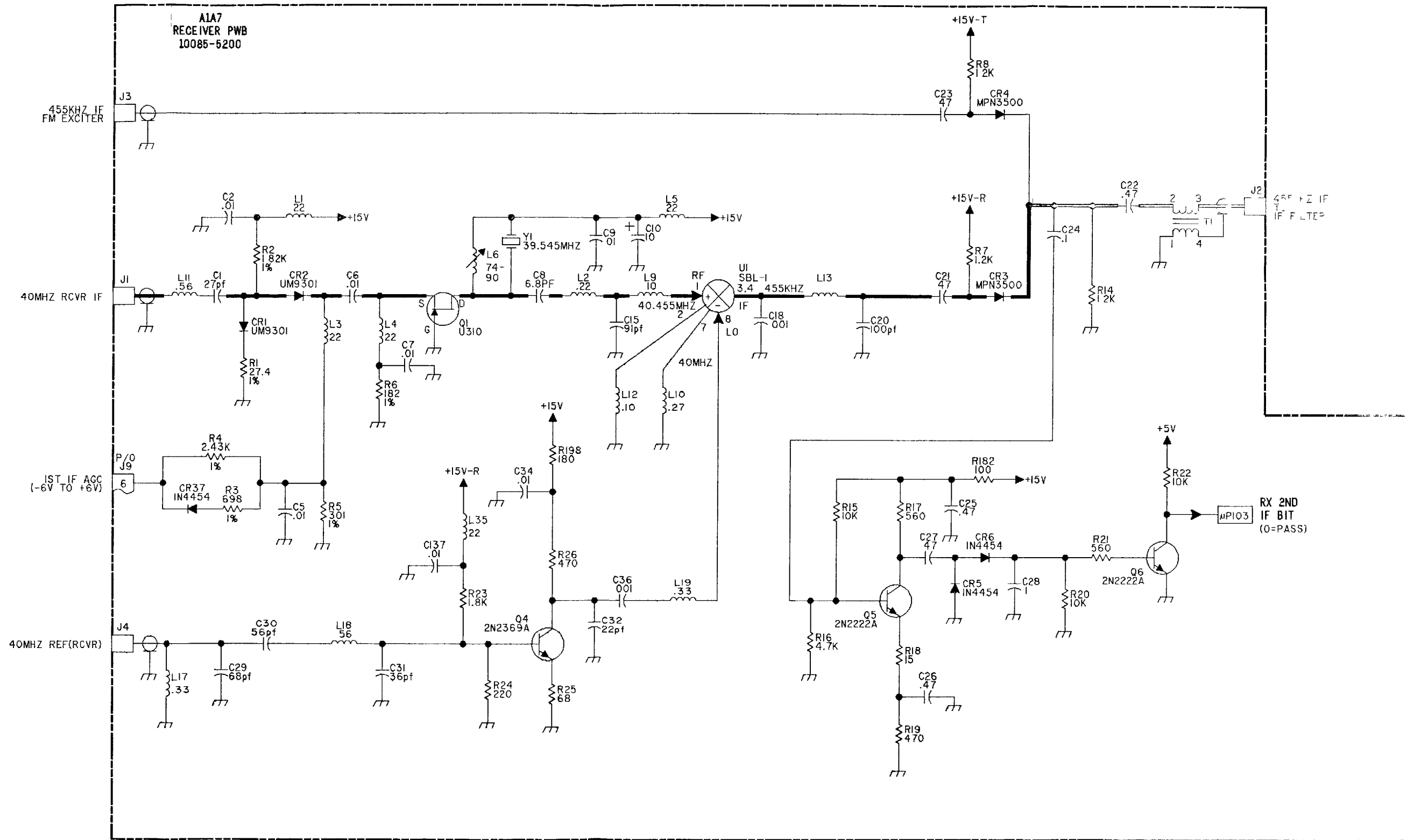
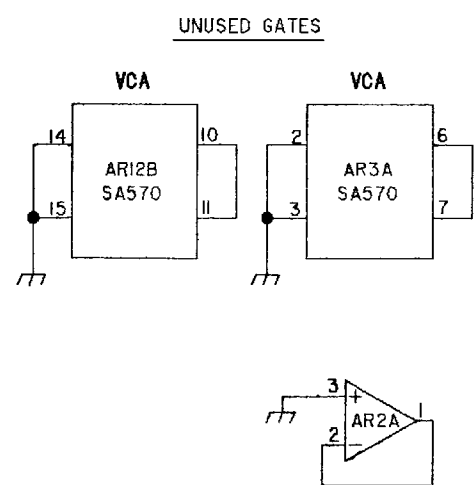

FO-9. RECEIVER PWB ASSY, A1A7 (Sheet 1 of 8)



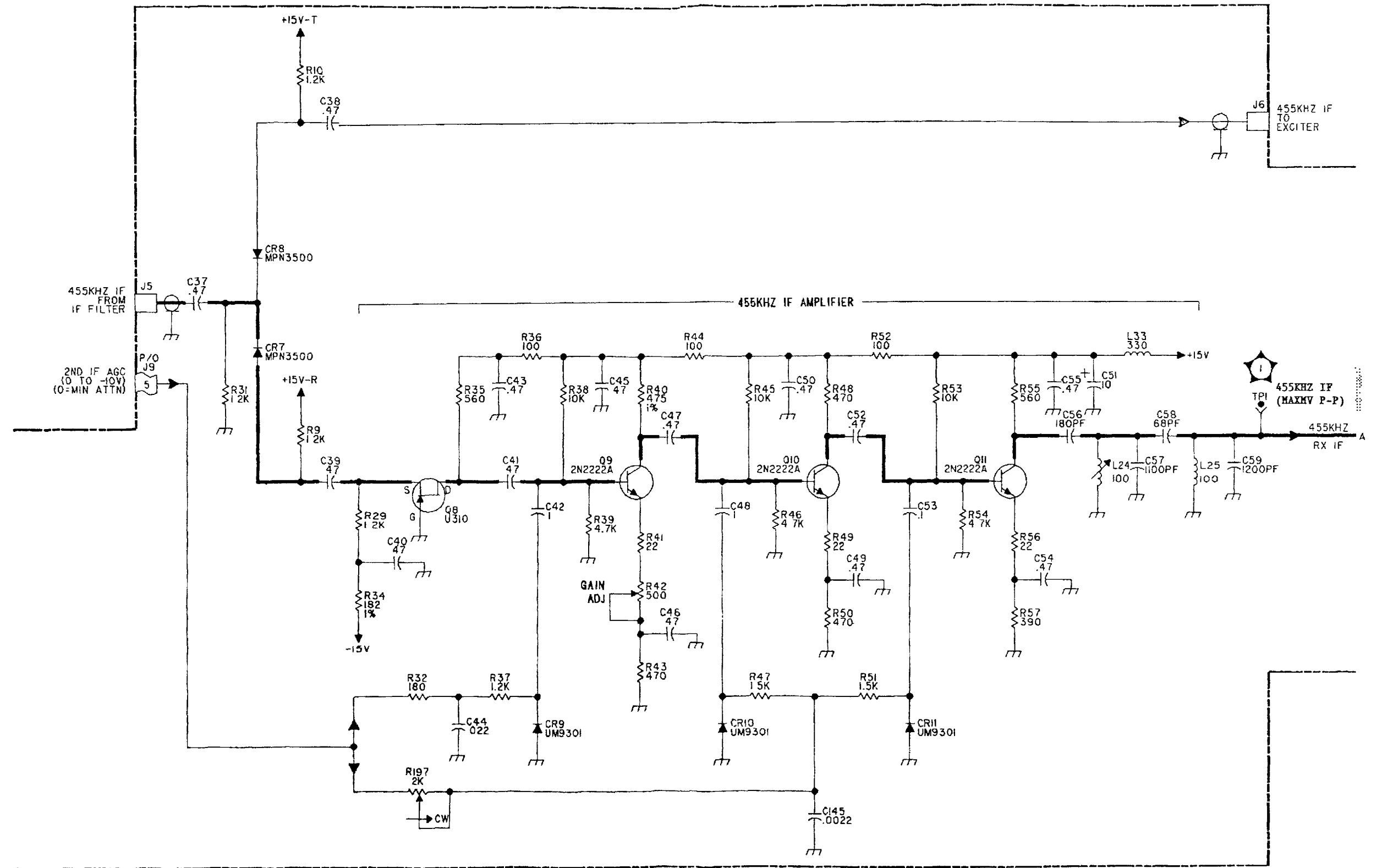

F9504417



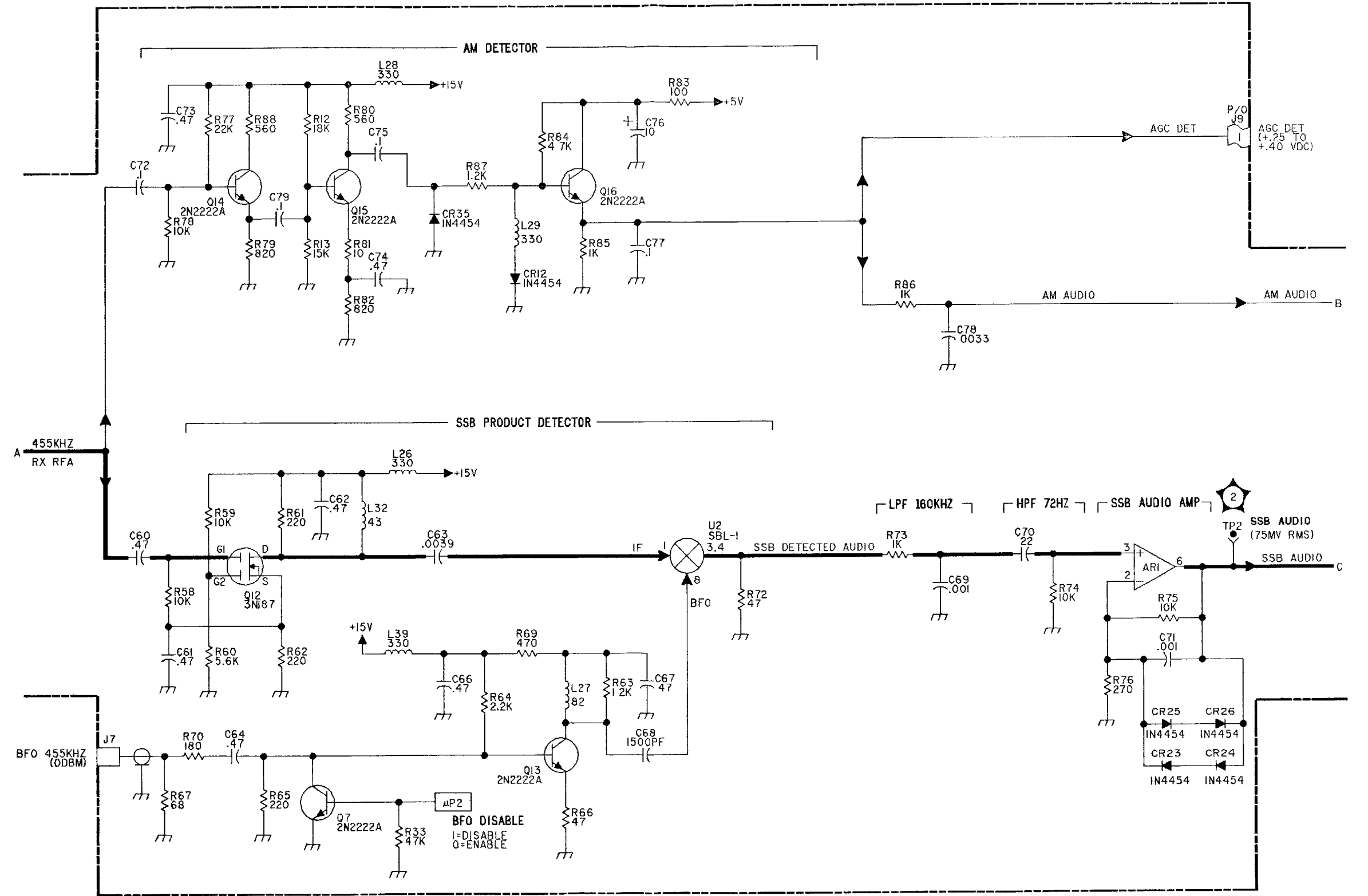

FO-9. RECEIVER PWB ASSY, A1A7  
(Sheet 3 of 8)



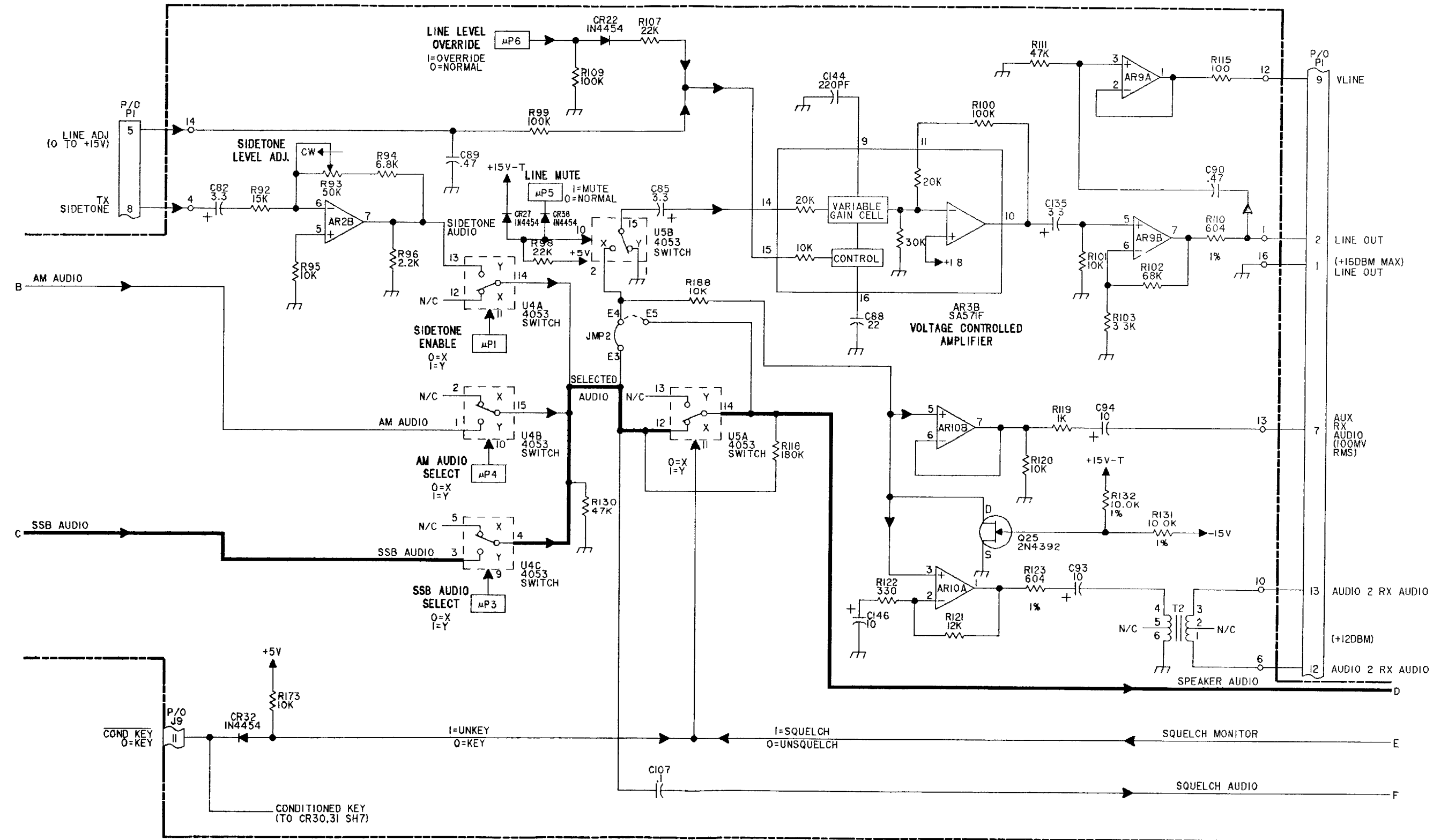

FO-9. RECEIVER PWB ASSY, A1A7  
(Sheet 4 of 8)





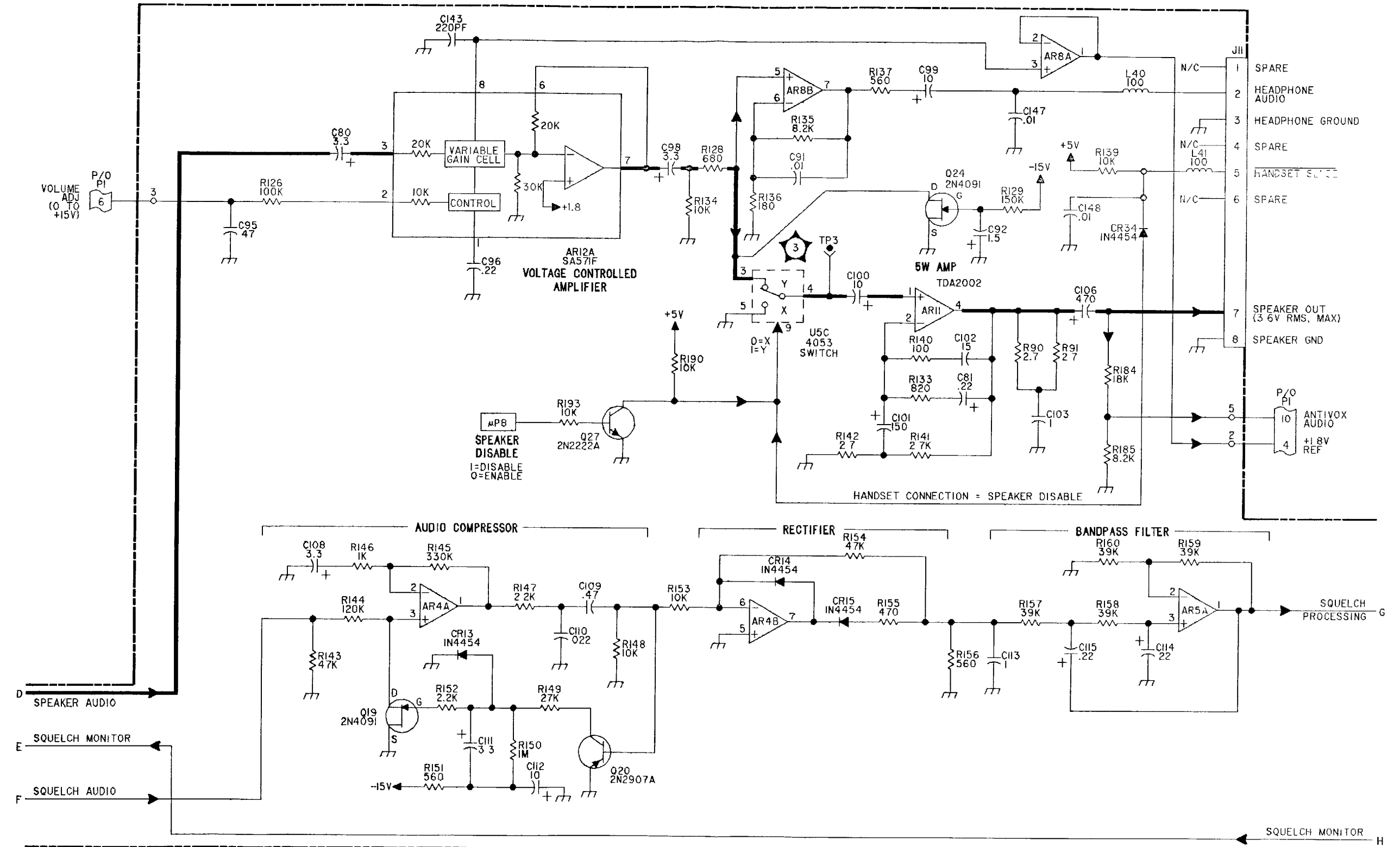

FO-9. RECEIVER PWB ASSY, A1A7  
(Sheet 5 of 8)



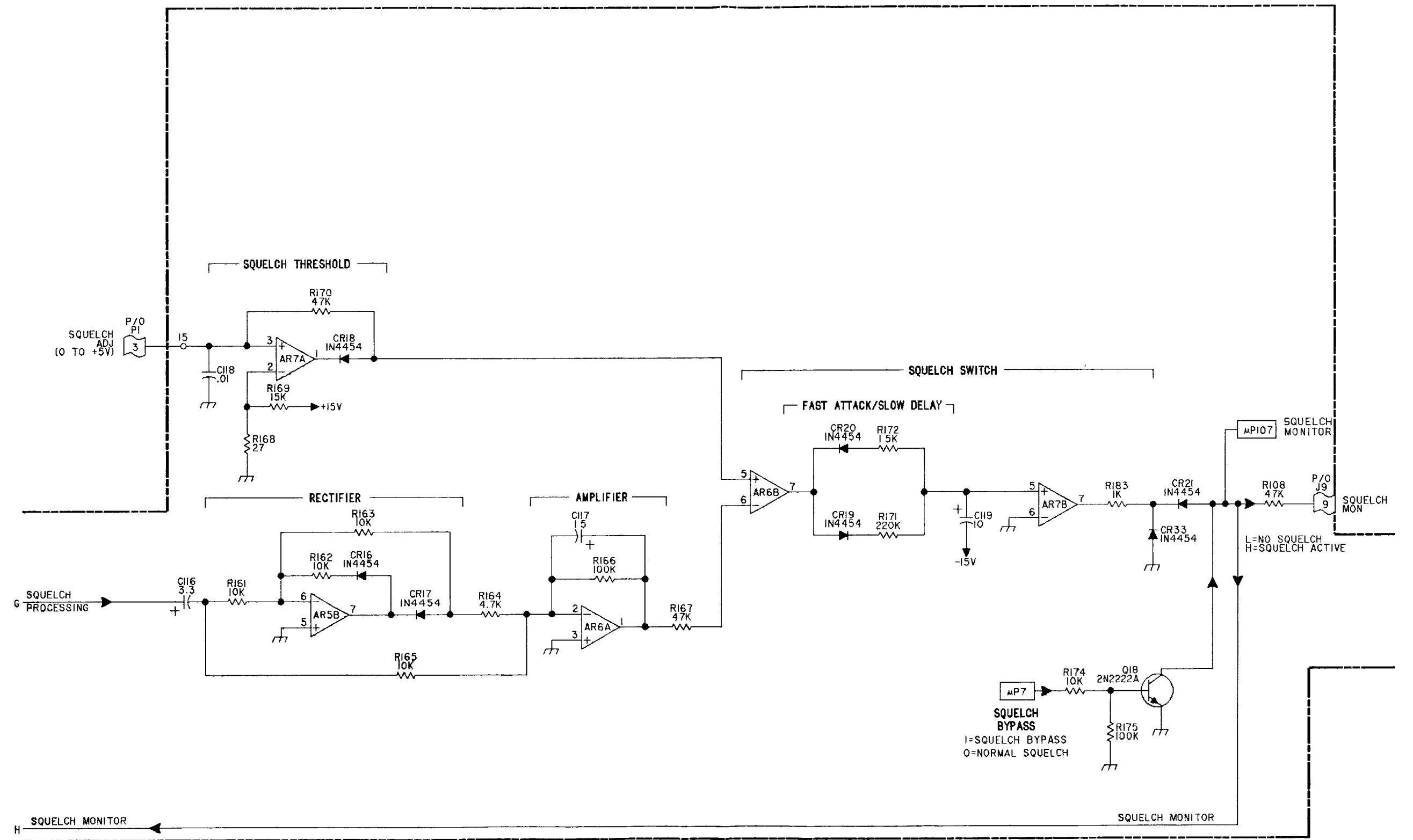

FO-9. RECEIVER PWB ASSY, A1A7  
(Sheet 6 of 8)



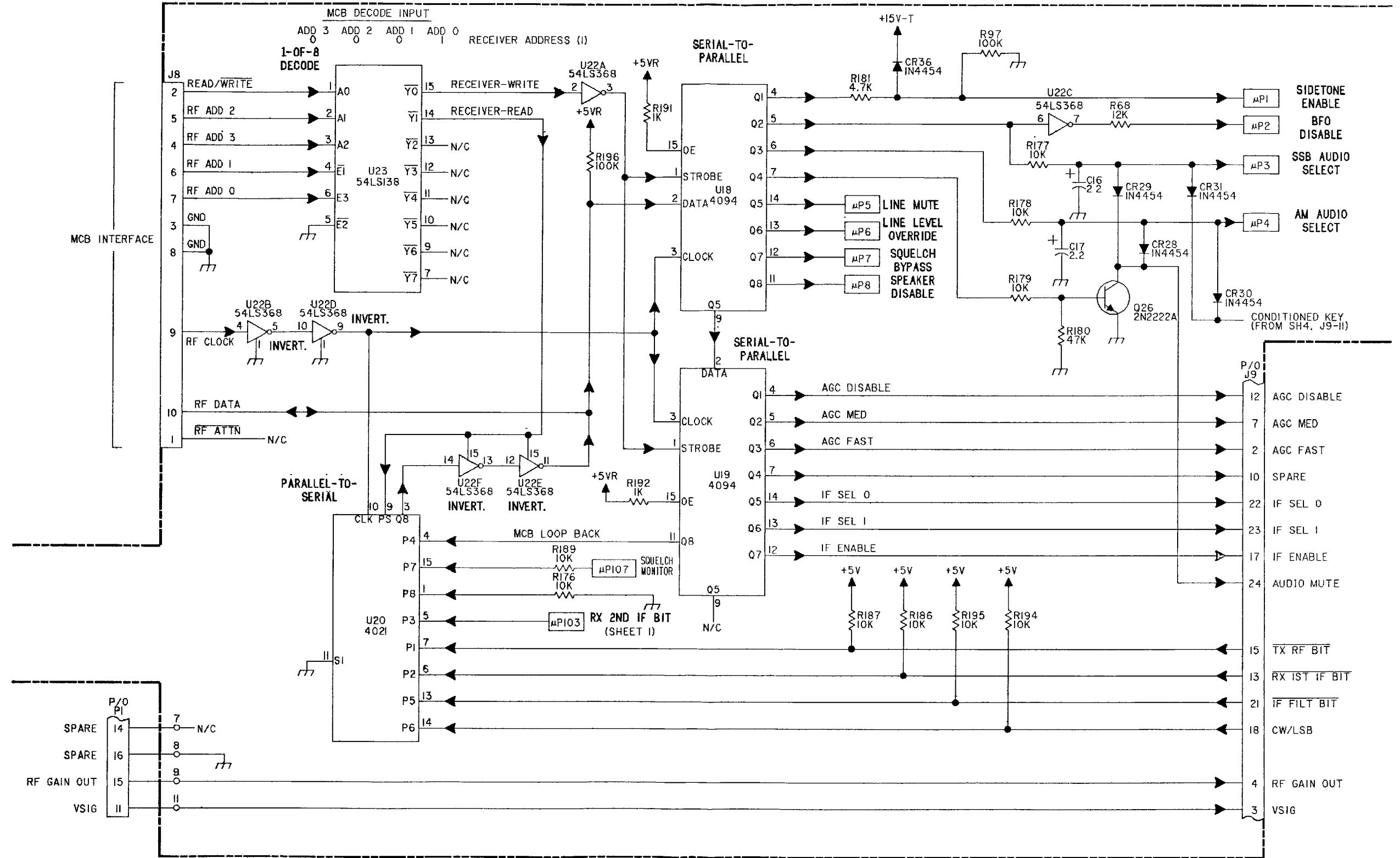

FO-9. RECEIVER PWB ASSY, A1A7  
(Sheet 7 of 8)



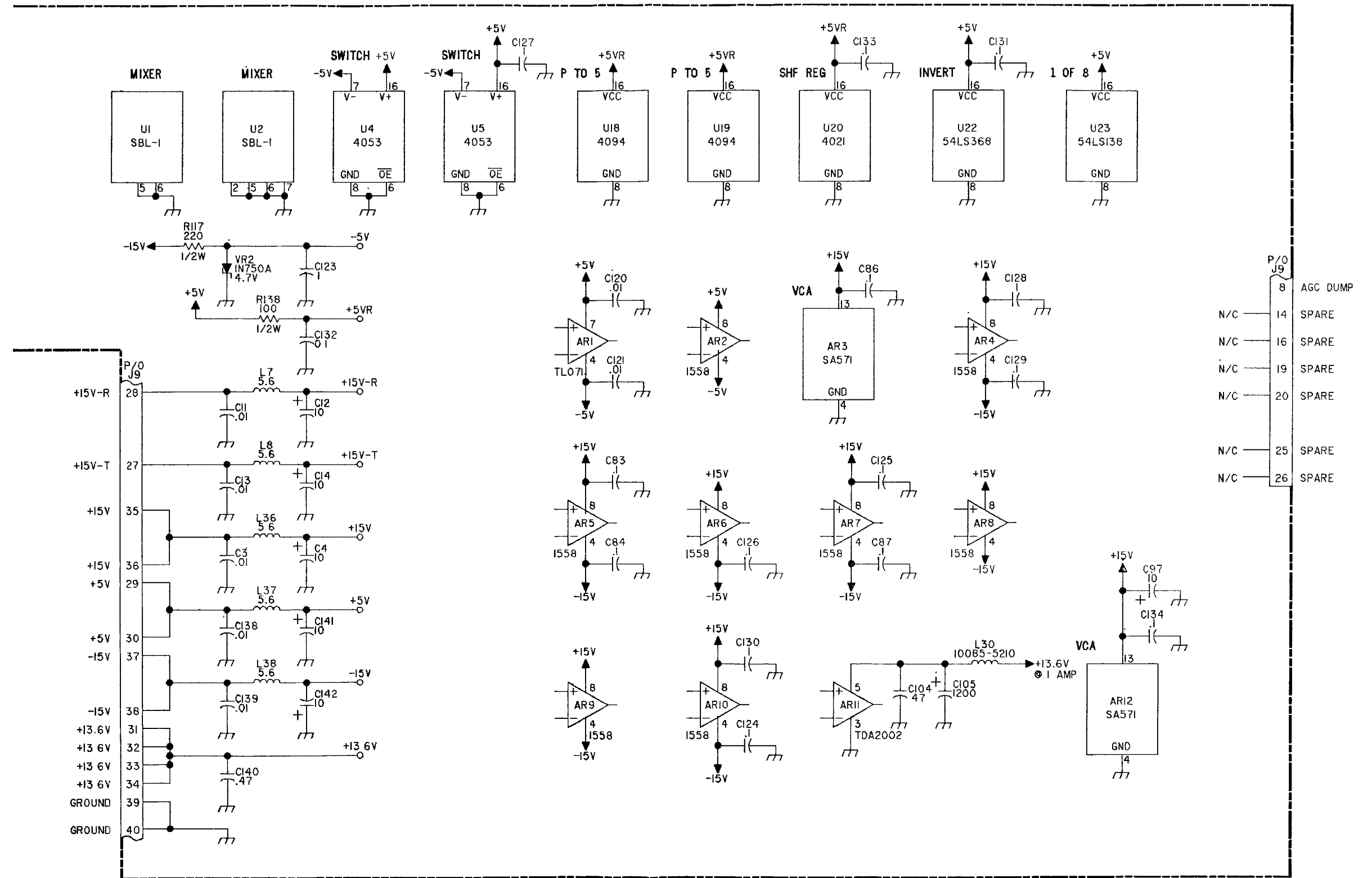

FO-9. RECEIVER PWB ASSY, A1A7  
(Sheet 8 of 8)





NOTE UNLESS OTHERWISE SPECIFIED

1. PARTIAL REFERENCE DESIGNATIONS ARE SHOWN FOR DETAIL PARTS. PREFIX THESE WITH UNIT NO. AND/OR ASSEMBLY DESIGNATIONS SHOWN ON DRAWING TO OBTAIN COMPLETE DESIGNATIONS.
2. ALL RESISTOR VALUES ARE IN OHMS. 1/4W. ±5%
3. ALL CAPACITOR VALUES ARE IN MICROFARADS (UF).
4. ALL INDUCTANCE VALUES ARE IN MICROHENRIES (UH).
5. VENDOR PART NO. CALLOUTS ARE FOR REFERENCE ONLY. COMPONENTS ARE SUPPLIED PER PART NO. IN PARTS LIST
6. DC RESISTANCES OF INDUCTIVE ELEMENTS (CHOKES, COILS, MOTOR WINDINGS, ETC.) ARE LESS THAN 1 OHM.
7. PANEL DECALS ARE INDICATED BY BOLD TYPE IN A BOLD BOX, E.G. **ON/OFF**.
8. ALL RELAYS ARE SHOWN IN THE DE-ENERGIZED STATE.

HIGHEST REFERENCE DESIGNATION			
REFERENCE DESIGNATIONS NOT USED			

UNUSED DEVICES

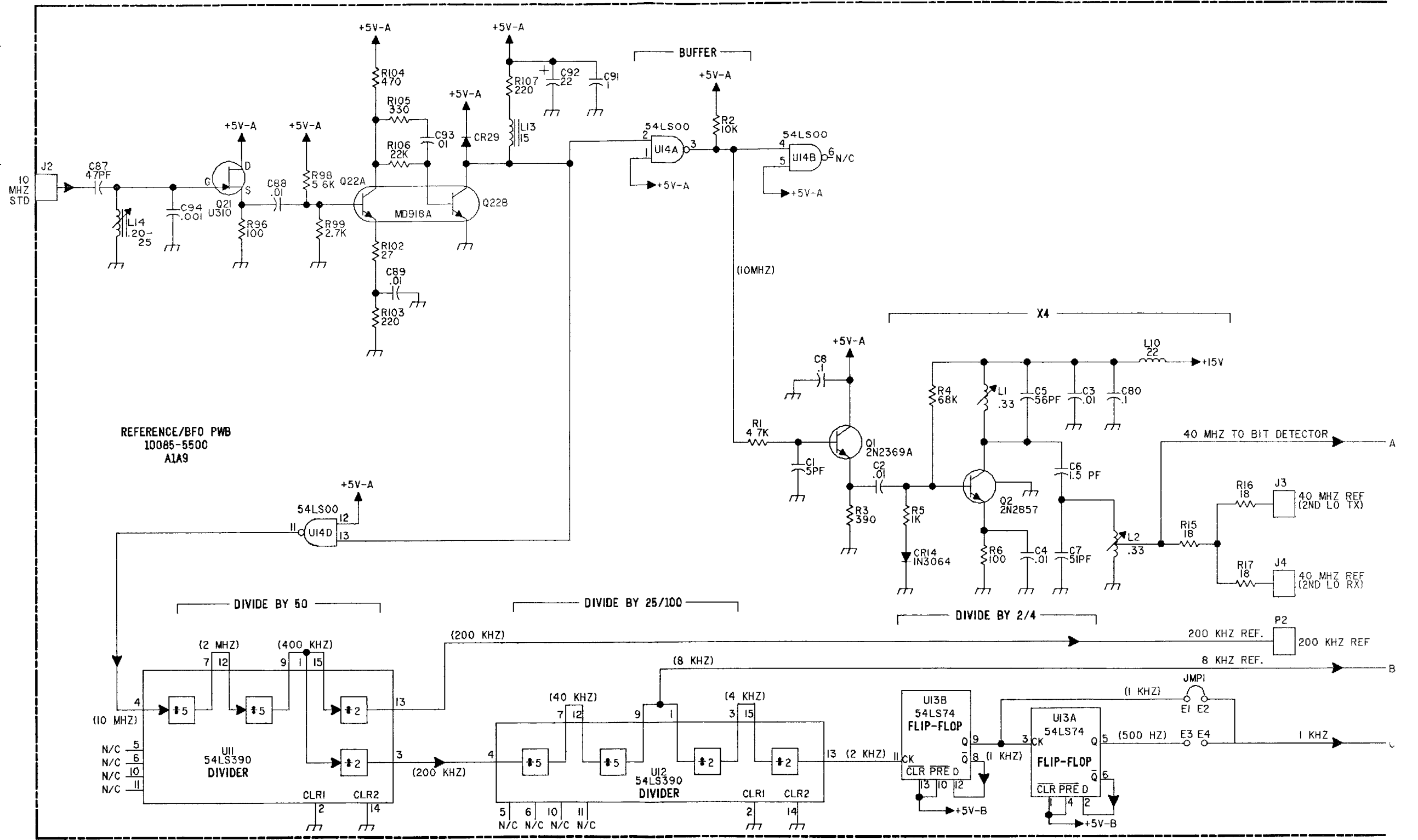
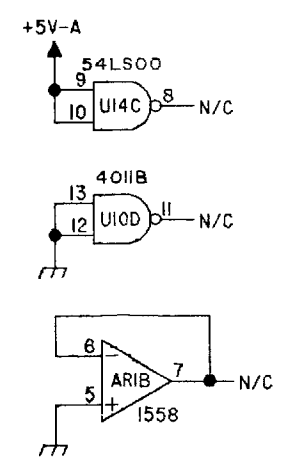

FO-10. REF/BFO PWB ASSY, A1A9  
(Sheet 1 of 6)



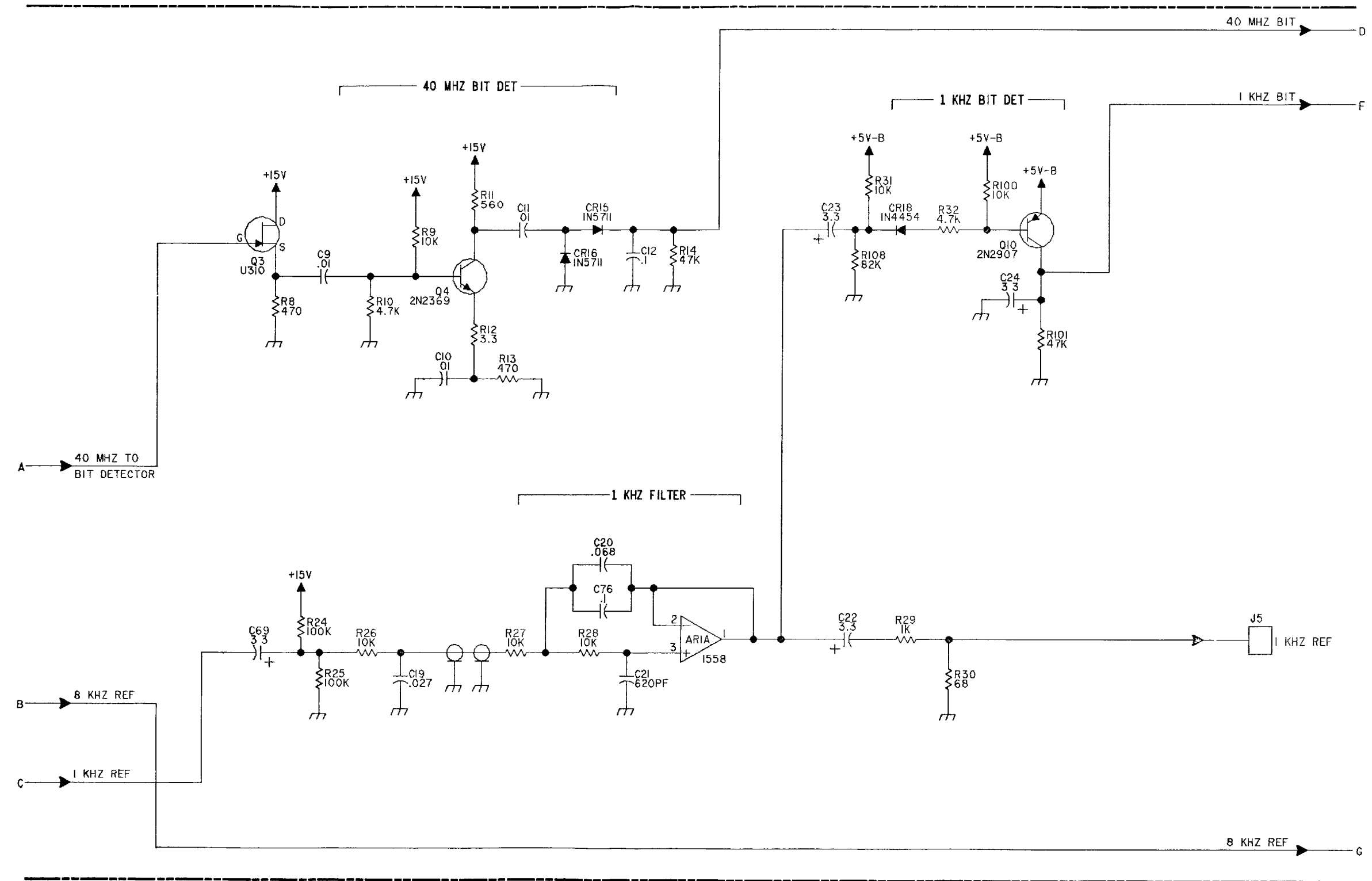

FO-10. REF/BFO PWB ASSY, A1A9  
(Sheet 2 of 6)

FP-105/(FP-106 Blank)



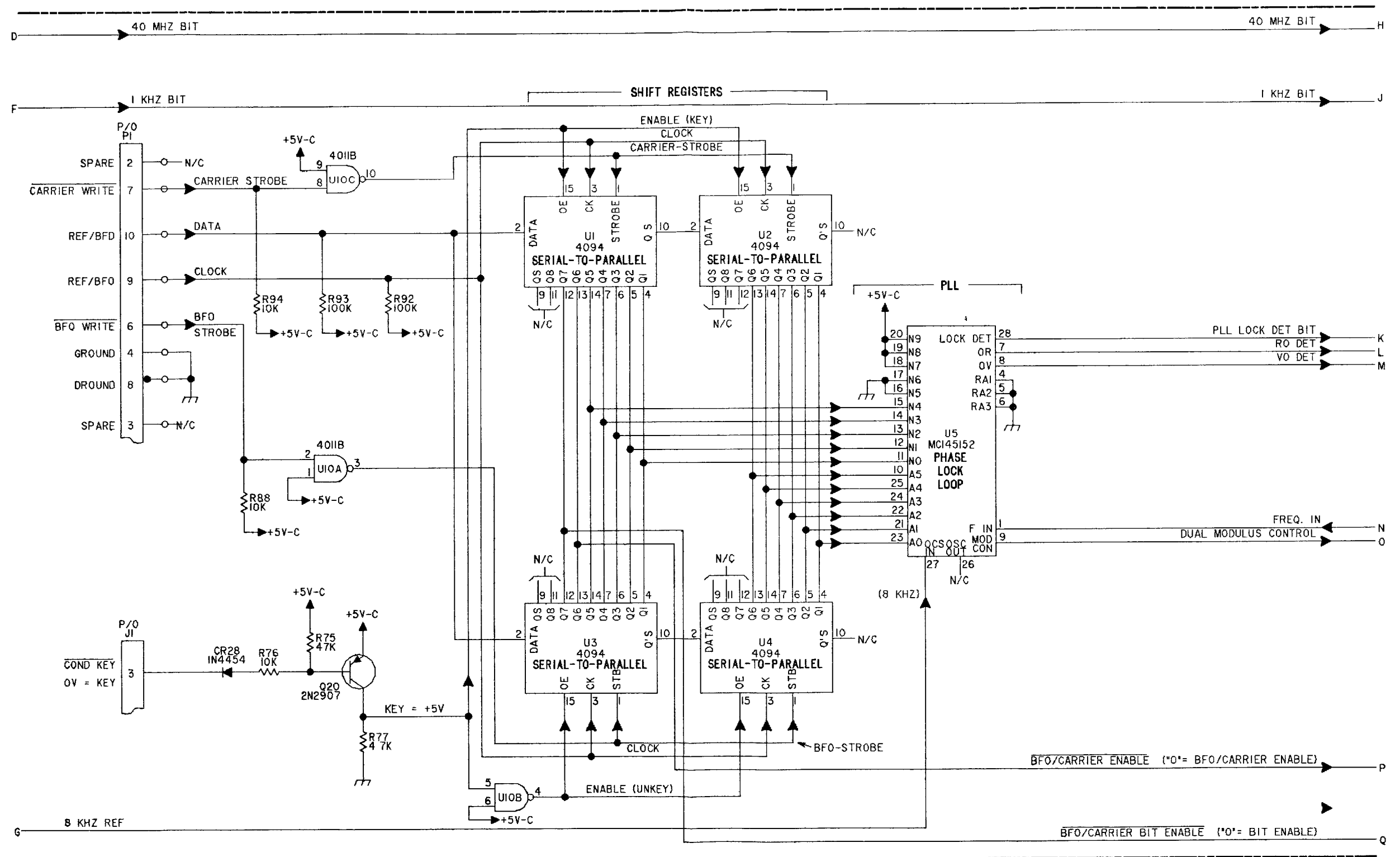

FO-10. REF/BFO PWB ASSY, A1A9  
(Sheet 3 of 6)

FP-107/(FP-108 Blank)



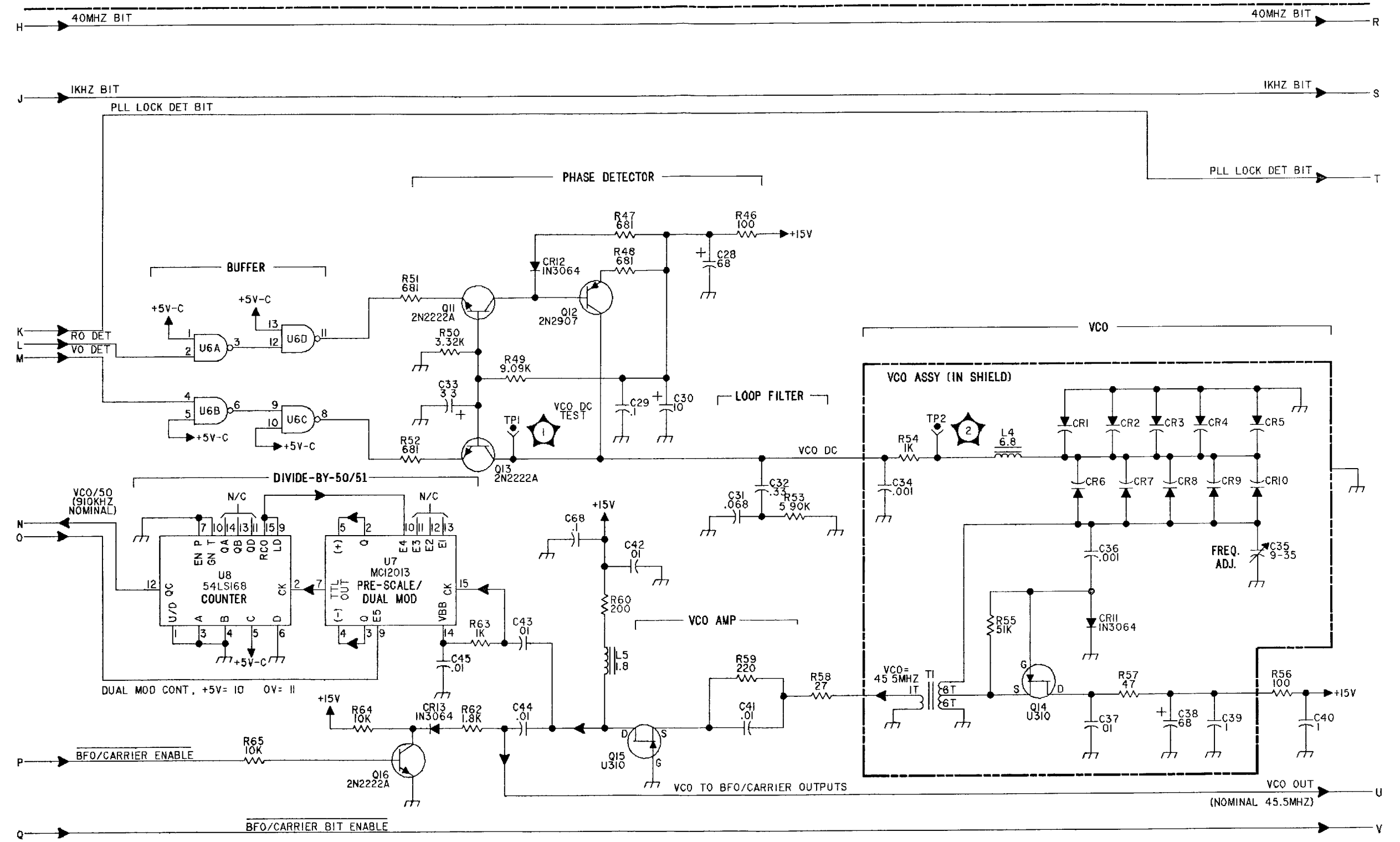

FO-10. REF/BFO PWB ASSY, A1A9  
(Sheet 4 of 6)

FP-109/(FP-110 Blank)





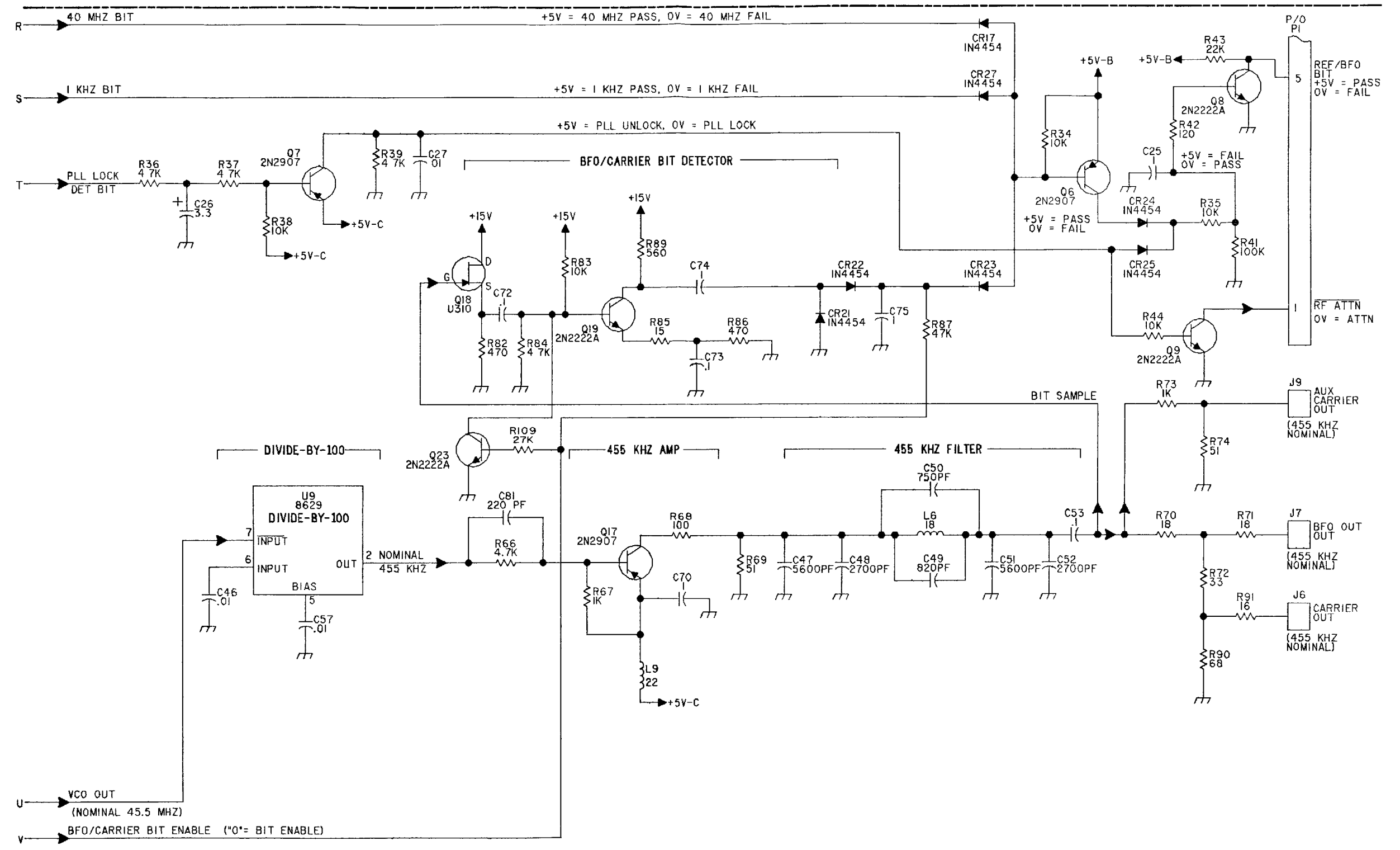

FO-10. REF/BFO PWB ASSY, A1A9  
(Sheet 5 of 6)

